

# Build this Frequency Standard/Reference Kit for \$12

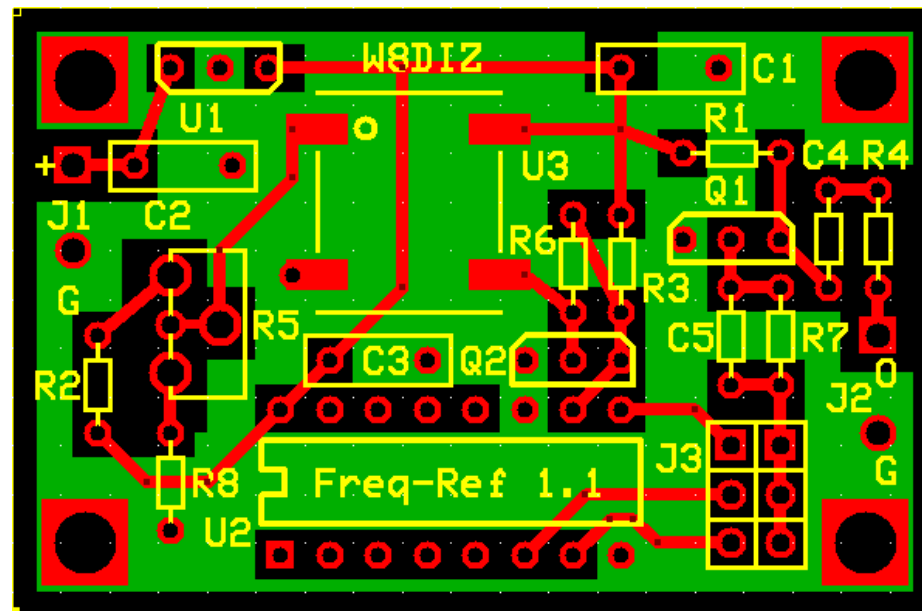
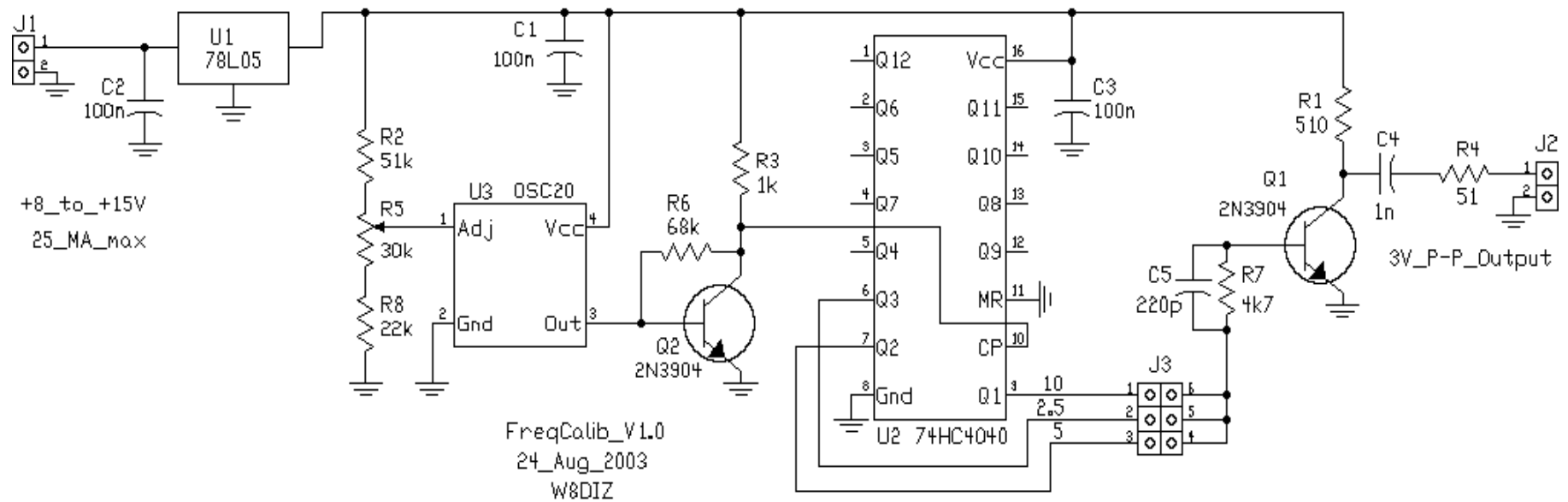

# Instructions for building the FREQUENCY STANDARD

INVENTORY all the parts against the parts list and check the box.

√		Qty.	Description	√		Qty.	Description
	Capacitors				Transistors		
	220 pF	1	C5		2N3904	2	Q1, Q2
	1 nF	1	C4				
	100 nF	3	C1, C2, C3		IC		
					74HC4040	1	U2
	Resistors				78L05	1	U1
	51 $\Omega$	1	R4		TCXO 20 MHz	1	U3
	510 $\Omega$	1	R1				
	1 k $\Omega$	1	R3		Hardware		
	4.7 k $\Omega$	1	R7		PCB	1	-
	22 k $\Omega$	1	R8		6 pin header	1	J3
	30 k $\Omega$ POT	1	R5		jumper	1	Red jumper
	51 k $\Omega$	1	R2		(16 pin socket)	1	-
	68 k $\Omega$	1	R6				

## STEP BY STEP INSTRUCTIONS (I)

- \_\_\_ Remove the 74HC4040 chip from the DIP socket on the PCB
- \_\_\_ Remove the 16 pin DIP socket from the PCB
- \_\_\_ Remove any residual Aluminum foil
  
- \_\_\_ Install the TCXO, matching the DOT on the PCB with the TCXO  
Place (melt) a very small amount of solder on **one** of the TCXO pads on the PCB, not the TCXO.  
Place the TCXO on the Pads and solder that pad in place.  
Solder the remaining pads of the TCXO.

## INSTALL ALL FIXED RESISTORS

___	R4	51Ω	Green	Brown	Black	Gold
___	R1	510 Ω	Green	Brown	Brown	Gold
___	R3	1 kΩ	Brown	Black	Red	Gold
___	R7	4.7 kΩ	Yellow	Violet	Red	Gold
___	R8	22 kΩ	Red	Red	Orange	Gold
___	R2	51 kΩ	Green	Brown	Orange	Gold
___	R6	68 kΩ	Blue	Gray	Orange	Gold

## STEP BY STEP INSTRUCTIONS (II)

### INSTALL ALL CAPACITORS

- \_\_\_ C5 220pF labeled 221
- \_\_\_ C4 1nF labeled 102

note: Straighten the pins on the blue 100n capacitors and mount flush on the PCB

- \_\_\_ C1 100nF labeled 104
- \_\_\_ C2 100nF labeled 104
- \_\_\_ C3 100nF labeled 104

### INSTALL THE 3x2, 6 PIN HEADER

- \_\_\_ J3 6 pin header

### INSTALL THE IC1. - This IC is STATIC SENSITIVE.

- \_\_\_ xx Install Socket for U2
- \_\_\_ U2 Insert the 74HC4040 IC into the socket

### INSTALL Transistors and Voltage Regulator

Push the next 3 devices about half way thru the PCB

- \_\_\_ U1 78L05 Match package outline with PCB
- \_\_\_ Q2 2N3904 Match package outline with PCB
- \_\_\_ Q1 2N3904 Match package outline with PCB

## STEP BY STEP INSTRUCTIONS (III)

### INSTALL BLUE POT.

Note: This is a single turn pot. Good enough for calibration.

The PCB has holes for a multiturn pot. You supply.

\_\_\_ R5 Install the blue 50 k $\Omega$  (30 k $\Omega$  on schematic) pot

### INSTALL POWER AND SIGNAL WIRES.

\_\_\_ Solder power supply wires (yours) labeled "+" and "G" at J1

Note that power supply voltage range is +7 to +15 VDC

\_\_\_ Solder RF output wires (yours) labeled "O" and "G" at J2

Use a twisted pair of wires or small coax like RG174

\_\_\_ Place red jumper over top 2 pins near C5 and R7 (10 MHz setting)

The middle pins are for 2.5 MHz and lower for 5 MHz.

Select whichever you want, but for calibration use 10 MHz.

## CALIBRATION

### CALIBRATE THE FREQ REF (using a WWV Receiver)

\_\_\_ Set a receiver to WWV on either 10 or 20 MHz.

20 MHz is best for daylight reception and 10 MHz is best at night.  
Not sure about the UK or Europe.

Power up the Freq Ref. Observe polarity.  
Use a 9v battery or a 12 volt source.

Let the reference stabilize for 2-3 minutes.

If you hear WWV in your receiver, also listen for the Freq Ref.

It should be within 1 kHz from WWV. If you can't hear it, verify that your Freq Ref is working with an oscilloscope.

Zero beat WWV with the Freq Ref signal by adjusting R5 until the heterodyne is beating at less than 1 Hz (1 beat per second).

# SUGGESTION FOR BOXING

